



# Privately Funded Sidewalk Program and General Permit



DRAFT

update to  
TTI Committee  
October 14, 2014





# PWE Asset Management Strategy: Sidewalks

## Level

## Scope/Program Component

### REPAIR

- Maintenance Impacts
- Remove Hazards

### REHABILITATE

- Safe Sidewalk Program  
(Pedestrian Accessibility Requests)
- Overlay Program  
(crossing pedestrian ways)

### RECONSTRUCT

- Street Reconstruction
- Safe Sidewalk Program  
(Thoroughfares and Schools)





# Common Causes of Sidewalk Problems

- Original construction quality
- Uncontrolled tree root growth
- Overloading—vehicular crossings
- Inconsistent irrigation practices
- Lack of landscaping care





# Goal to Improve Shared Responsibility

- Make it easier for property owners to make repairs/complete gaps
- Increase availability of Houston sidewalks
- Reduce obstructions within the public pedestrian way





# Privately Funded Sidewalk Repair, Replace and Installation Program

## SCOPE OF PROGRAM:

- Similar to scope of current safe sidewalk program; will include both replacement & new sidewalk
- Requires letter of request & payment from abutting property owner or property association
- Excludes new home construction





# Privately Funded Sidewalk Repair, Replace and Installation Program

## PROCESS:

(Citizen) Requests thru PWE Website

(PWE) Assesses Site for constructability

(PWE) Reports to Requestor (~1 month)

(Citizen) Submits payment

(PWE) Releases work order to contractor

(PWE) Oversees contractor delivery





# Privately Funded Sidewalk Repair, Replace and Installation Program

## INFORMATION:

Website with Program Information,  
Process, and Request Form

CitizensNet Notification

Outreach in coordination with  
Department of Neighborhoods







# Estimated Cost

	<b>Length</b>	<b>Construction Cost</b>	<b>City Cost</b>	<b>Total Cost</b>
Low	3 Panels- Approx. 15ft	\$700	\$100	<b>\$800</b>
Medium	Lot Width- Approx. 60ft	\$4,100	\$1,100	<b>\$5,200</b>
High	Block- Approx. 400ft	\$26,000	\$4,000	<b>\$30,000</b>

\*City costs include Design, Management, Material Testing, etc.







# General Permit Residential Sidewalk Self Repair

## Conditions & Guidance

- Repair/Replacement on SFR properties only
- Ordinance Change: No permit fees
  1. Must have an existing sidewalk
  2. Limits of repair/replacement only on property of application
  3. Excludes sidewalks through driveways





# Revised Requirements

## On-Line Application Package

- Notice of Repair: Two business days prior to construction
- Simple detail for sidewalk construction
- Notice of Completion: Work is finished

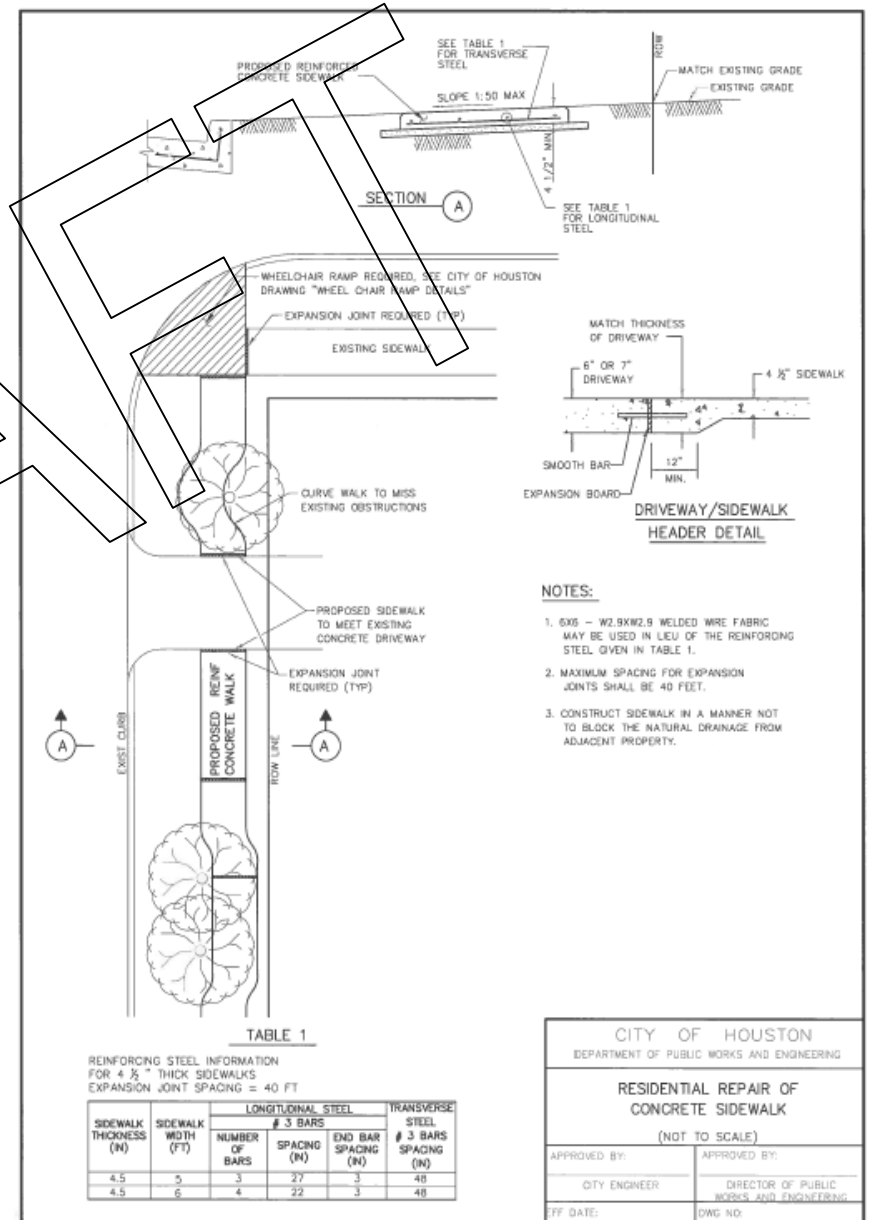



# Sidewalk Specifications

- Repaired at its existing width
- Reconstructed to City standards
- Repairs near existing trees, permit user shall contact HPARD, Urban Forestry
- No formal inspection





## Next Steps

Council action General permit	Nov 2014
General permit to be effective	Dec 2014
Award contract(s)	Jan 2015
Open for requests	Feb 2015

